

Bolondi
Cleaning Heads

*Cleaning heads for washing
at high and low pressure*

rotojet[®]

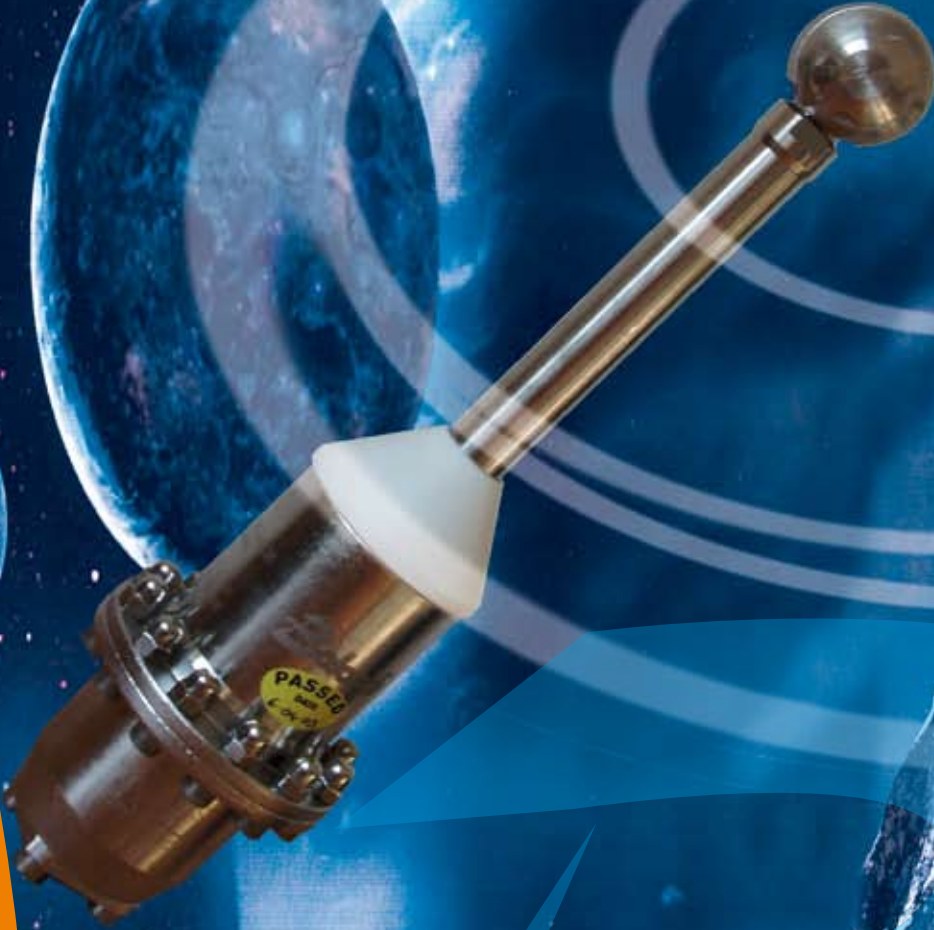

NEW

rotojet[®]

**evolution
of a technological
history**

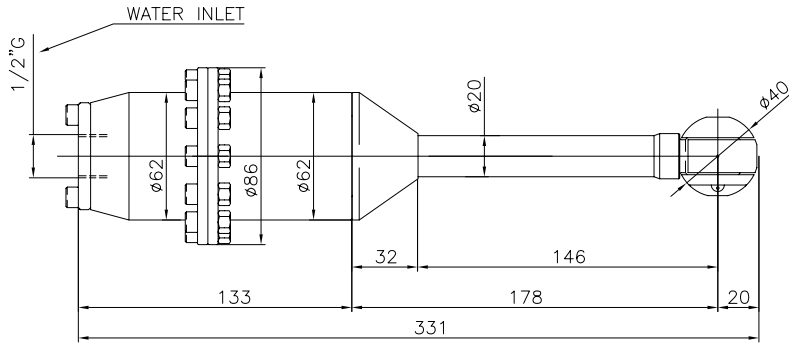

TECHNICAL DATA	
O.RING	EPDM
SLIPPER	PTFE+CARBON FIBRE
FILTER	NONE
NOZZLES POSITIONS	2 OR 4
NOZZLES TYPE	SPECIAL NOZZLE XB 030
MAX OPERATING FLOW	30 L/min - 8 USG/min
MAX OPERATING PRESSURE	150 bar - 2100 psi
MAX OPERATING TEMPERATURE	90 °C - 194°F
MATERIAL	INOX AISI 316
LUBRICANTS	NONE
CONICAL GEARS	FIXED Z=23 ROTATING Z=25
MODULE	1
COMPLETE CYCLE	25 ROTATIONS
COMPLETE CYCLE TIME	1.1 MIN.
ROTATION SPEED	24 RPM
WEIGHT	4.6 KG - 10 LBS

NEW

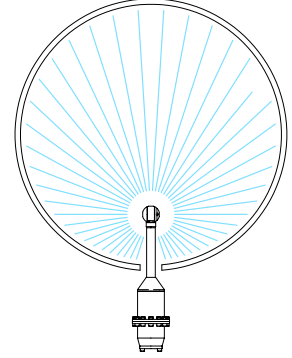
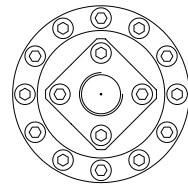

Code
XB 031 AAD 01

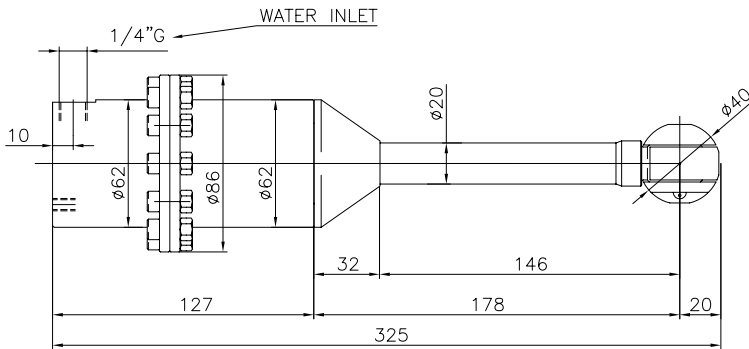

TECHNICAL DATA	
O.RING	EPDM
SLIPPER	PTFE+CARBON FIBRE
FILTER	NONE
NOZZLES POSITIONS	2 OR 4
NOZZLES TYPE	SPECIAL NOZZLE XB 030
MAX OPERATING FLOW	30 L/min - 8 USG/min
MAX OPERATING PRESSURE	150 bar - 2100 psi
MAX OPERATING TEMPERATURE	90 °C - 194°F
MATERIAL	INOX AISI 316
LUBRICANTS	NONE
CONICAL GEARS	FIXED Z=23 ROTATING Z=25
MODULE	1
COMPLETE CYCLE	25 ROTATIONS
COMPLETE CYCLE TIME	1.1 MIN.
ROTATION SPEED	24 RPM
WEIGHT	4.6 KG - 10 LBS

NEW

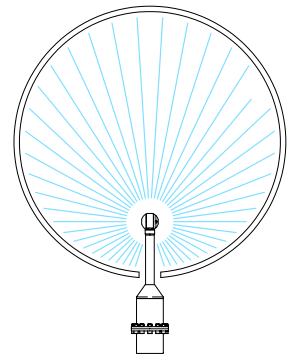
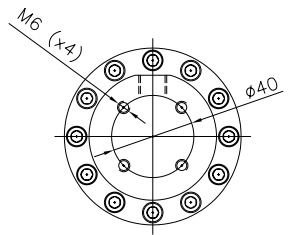

Code
XB 031 AAE 01