

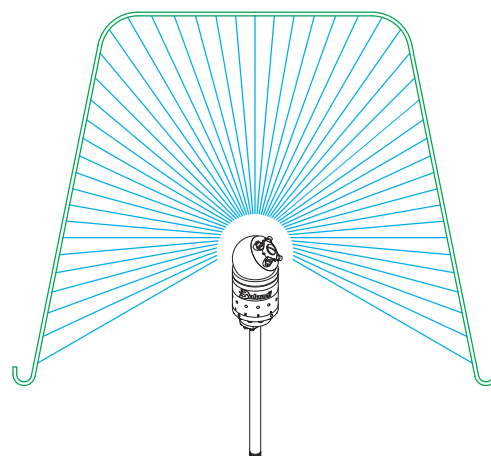

CE

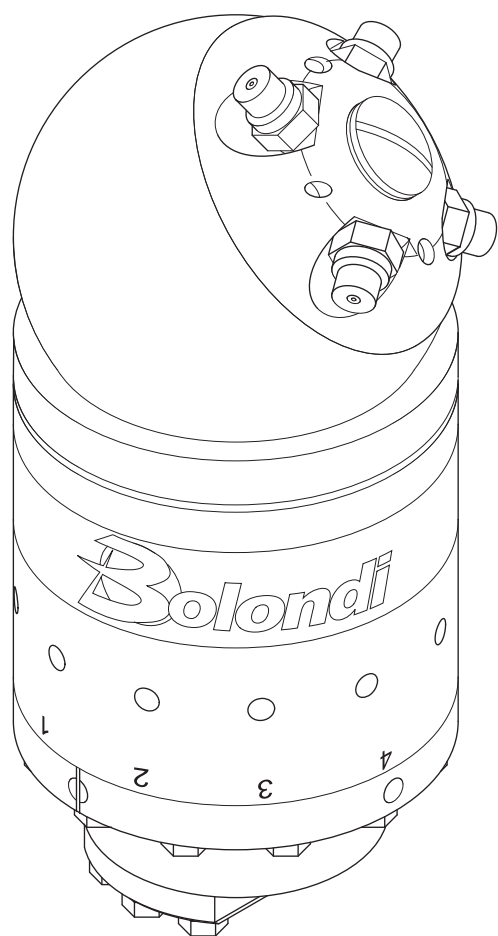

INSTRUCTION MANUAL HEADS MOD. SW 060-CF.09

SERIAL N°: XXXXXXXXX



WARNING: THIS MANUAL IS AN INTEGRAL PART OF THE MACHINE AND MUST BE READ AND KEPT FOR REFERENCE.

Translation of the original instructions

SW 060-CF.09-MANUAL Rev.00

INTRODUCTION

- DECLARATION OF INCORPORATION OF INCOMPLETE MACHINES3
- REFERENCE LEGISLATION4
- TERMS OF WARRANTY5
- 1) INTRODUCTION6
- 2) RECEIVING AND UNPACKING7
- 3) CONDITIONS AND LIMITS OF USE8
- 4) GENERAL SAFETY INSTRUCTIONS9
- 5) TECHNICAL SPECIFICATION10
- 6) DIAGRAM OF THE ASSEMBLY12
- 7) INSTALLATION AND COMMISSIONING (WARNINGS)13
- 8) SPINNING SPEED CONTROL14
- 9) MAINTENANCE15
- 10) SPARE PARTS23
- TABLE "B" TORQUE WRENCH SETTINGS24
- EXPLODED VIEW25
- NOTES26

DECLARATION OF INCORPORATION OF INCOMPLETE MACHINES

The undersigned Bolondi Ivano in his role of Legal Representative of Officina meccanica Bolondi Ivano and Person authorised to constitute the technical folder, DECLARES under his own responsibility that the material supplied, indicated in this manual and to which this declaration refers, consists of a washing head that complies with:

- The applicable essential safety requirements (1.1.2 – 1.1.3 – 1.1.5 – 1.3.1 – 1.3.2 – 1.3.3 – 1.3.4 – 1.3.9 – 1.5.1 – 1.5.2 – 1.5.3 – 1.5.4 – 1.5.6 – 1.5.7 – 1.5.8 – 1.5.13 – 1.5.14 – 1.6 – 1.7) of appendix I of machinery directive 2006/42/EC
- The applicable essential safety requirements of directive 2014/68/UE (pressurised equipment classified in art. 4 cat. 3)

It also complies with the following harmonised European standards:

ISO TR 14121-2:2013 - Guidance document for risk assessment

UNI EN ISO 12100:2010 - Safety of machinery - General principles for design.

The undersigned also declares that the incomplete machine cannot be started-up until the machine on which it will be incorporated and of which it will become part has been identified and declared to be compliant with the provisions of directive 2006/42/EC; in other words until the incomplete machine to which this declaration refers has become an integral part of the end machine.

The pertinent technical documents have been drawn-up in compliance with appendix VII B. We shall forward the information concerning the incomplete machine by fax, e-mail or other means following a reasonable request from National authorities.

(00A-01CE-00-EN)

BOLONDI IVANO
The legal representative
Ivano Bolondi



REFERENCE LEGISLATION

AIRBORNE NOISE AND VIBRATIONS:

Sound intensity measurements relating to the noise produced by the machine were taken in compliance with DIR. 2006/42/CE.

The acoustic pressure was measured at the workstation, at 1 m from the machine surface and 1.6 m off the ground, in normal machine operating conditions.

Sound intensity measurements gave readings below 70 dB(A).

Measurement of vibrations was not made as these were considered clearly below risk levels.

The intensity of the sound produced by machine operation is normally below sound intensity caused by the impact of washing water against the walls to be washed.

(00D-LdrCE-00-EN)

TERMS OF WARRANTY

- 1) The manufacturer guarantees the rotating head to be free of manufacturing or material defects.
- 2) Warranty: 2 years for EC countries, 1 year for countries outside the EC (valid from date of delivery).
- 3) The warranty excludes: all parts subject to normal wear, damage due to carelessness or improper use.
- 4) The validity of the warranty shall be decided indisputably by the manufacturer.
- 5) The warranty excludes labour and transport costs, which are always the responsibility of the purchaser.
- 6) All spare parts replaced under warranty must be returned to the manufacturer, carriage paid, within a maximum of 20 days.
- 7) The warranty on the finished product or its components shall be void if the product is tampered with, modified, or has parts manufactured by third parties installed on it without prior authorisation from Bolondi.
- 8) Competent court: Judicial Authority of the court of Reggio Emilia, Italy
(00C-Garanzia-00-IT)

1) INTRODUCTION

Read this operating and maintenance manually carefully before using the head. Only by following the instructions herein and becoming familiar with the symbols used is it possible to obtain conditions of maximum efficiency and safety. The contents of this manual are in compliance with machine directive 2006/42/CE and subsequent amendments. The Manufacturer reserves the right to make any modifications without notice and without incurring any sanctions on condition that the main technical safety features are not affected. The Manufacturer is not responsible for personal injury or material damage resulting from the non-observance of the indications that accompany the symbol.



The symbol  represents a safety warning. Failure to follow the instructions given can cause serious personal injury.

N.B.:

For accident prevention purposes the equipment must be fitted with suitable devices to prevent automatic re-starting when the equipment is powered after a shut-down. The head must not be used without these devices. The Manufacturer declines all responsibility in the case of improper use of the equipment.

N.B.:

Please consult the chapter EXPLODED VIEW for all the numbers and references in the manual.

(01-000-00-EN)

2) RECEIVING AND UNPACKING

2.1) CHECKING AND UNPACKING

2.1.1) On receipt, make sure that the model and technical specifications correspond with the order.

2.1.2) Make sure that goods were not damaged during transport.

2.1.3) Any damage found when the goods are received must be documented and the sender informed within 3 days of receipt.

2.1.4) Disposal of packaging: the purchaser is responsible for following the correct procedure and applicable regulations in their country for disposing of the consumables and refuse created by unpacking the product.

INSTRUCTIONS FOR CORRECT WASTE MANAGEMENT.

Material: Paper and cardboard (EWC code 15 01 01)

Plastic (EWC code 15 01 02)

Wood (EWC code 15 01 03)

2.2) DEMOLITION AND DISPOSAL

It is the purchaser's responsibility to follow the correct procedure and comply with the current laws in force in his country as regards to disposing of consumables and materials resulting from demolition.

Please remember that by waste is meant any substance or object under obligation of disposal.

According to their origin and pursuant to the above mentioned Decree, waste products are classified as urban or special waste and, depending on their dangerous characteristics, as hazardous or non-hazardous waste.

Waste resulting from the demolition of the machine is classified as special waste.

WARNING! It is forbidden to mix together different categories of hazardous waste and hazardous waste with non-hazardous waste.

INSTRUCTIONS FOR THE MOST APPROPRIATE HANDLING OF WASTE.

Ferrous materials (EWC code 17 04 05)

As this is recyclable material (secondary raw materials), it should be taken to an authorised collection centre.

Plastic materials (EWC code 16 02 16)

Recycling permitted where landfill disposal is performed for urban-type waste.

Incineration permitted in plants equipped with post-combustion and fly-ash capture systems.

Follow applicable national legislation, as amended.

(02-000-00-EN)

3) CONDITIONS AND LIMITS OF USE

3.1) Never point the jet of water at people, animals or electrical parts.

3.2) Always check that the equipment and the safety features are in good working before using the machine. It is forbidden to use the equipment if it is not in perfect condition.

3.3) Intended use: the head was designed exclusively for washing closed containers.

3.4) Improper use: any other use that does not comply with the safety standards indicated in this manual is to be considered improper.

3.5) Declaration of the manufacturer: if the head is installed, as a component, on machines or systems, it is forbidden to use it before the latter have been declared to comply with the provisions of the Machine Directive.

(03-000-00-EN)



4) GENERAL SAFETY INSTRUCTIONS

- 4.1) The equipment must be started only by personnel in charge of the plant and only after it has been validated.
- 4.2) Ensure that the device is securely blocked by the flanging.
- 4.3) When the equipment is inside the container or plant, check that it does not collide with any of the moving parts.
- 4.4) Before start-up, check that all the openings, valves, etc., are closed and allow no pressurised jets escape.
- 4.5) Make sure the supply pipes and connection fittings are suitable for the working pressures/flow rates and for the type of fluids used.
- 4.6) Ensure that the screwed coupling of the connecting hoses is airtight.
- 4.7) Make sure the supply motor pump is fitted with a relief valve and its setting is compatible with the head.
- 4.8) Make sure the quantity and diameter of the nozzles are suitable for the characteristics of the plant (pump pressure and flow).
- 4.9) The high pressure hose must be perfectly intact (to avoid the risk of bursting). If the high pressure hose is damaged, it must be replaced immediately.
- 4.10) Do not inspect the container or plant when the head is working or in the presence of considerable quantities of vapour.
- 4.11) Each time before using and after each use, make sure the screws are perfectly tight. **See table B “tightening torques”.**



- 4.12) The symbol  marked on the head draws the operator's attention to situations that could jeopardise workers' safety.
- 4.13) The general safety and accident prevention regulations laid down by law must be observed, as well as the warnings given in the operating instructions.

(04-000-00-EN)

5) TECHNICAL SPECIFICATION

FLOW MAX	60 L/MIN
PRESSURE MAX	200 BAR
HYDROSTATIC TEST PRESSURE	340 BAR
MAX OPERATING TEMPERATURE	90 °C
WATER INLET	1/2" COAXIAL
FILTER	700 MICRON
NUMBER OF NOZZLES	2 - 4
NOZZLES	1/8" NPT
O.RING	NBR - EPDM - VITON
SEALS	PTFE + CARBON FIBRE
BUSHING	B14
MATERIAL	ALUMINIUM - BRASS OT58 - AISI 316
MIN.CENTER LINE THROUGH HOLE	100 MM
POSITIONS OF THE DIFFUSER	4
ROTATION SPEED	70 ÷ 120 RPM (SEE CHAPTER 8)
FULL CYCLE	61 ROTATIONS
FULL CYCLE TIME	36 SEC. A 100 RPM
WEIGHT	KG. 3,750
*IMPORTANT: CYCLE TIME DEPENDS ON ROTATION SPEED	

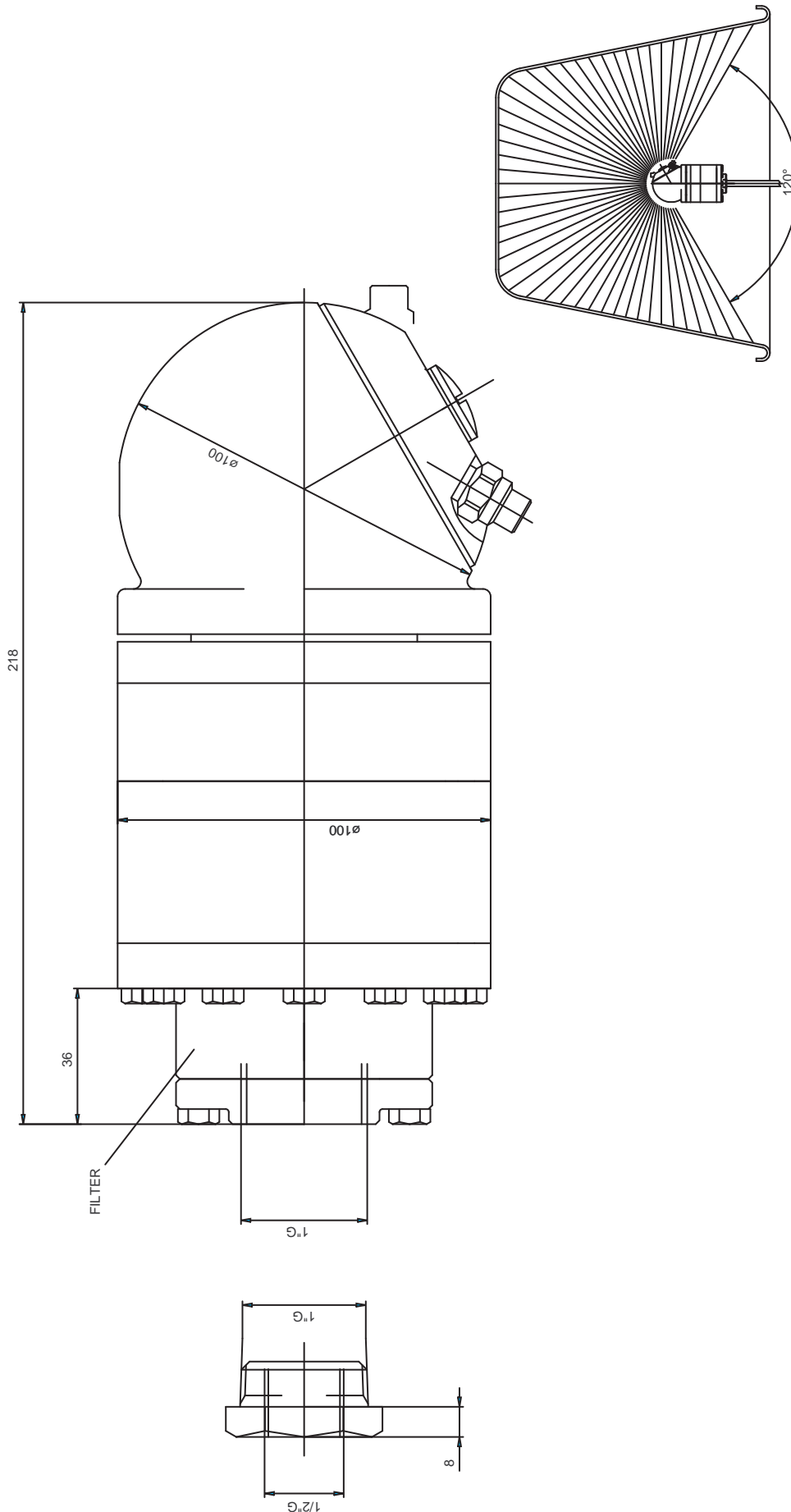

RUGOSITA' (UNI 4600) GREZZO = ∇ SGRASS. = ∇ FINITURA = ∇ RETTIFICA = ∇	MODIFICA 1 FOGGIO XXXX DATA XXXX.XX TOLLERANZE GENERALI classe m UNI-EN 22768/1 0-6 130-120 120-400 400-1000 1000-2000 + 0.1 + 0.2 + 0.3 + 0.5 + 0.8 + 1.2 NOTE: VERSIONE 06 MATERIALE: INOX+ALLUMINIO DESCRIZIONE: AQUAMOTOR SECTOR OPEN CONTAINER VERSION NON WASHED HOLLY GONE 120°	2 3 4 5	5
Bolondi CLEANING HEADS MONTECCHIO E. (RE) - ITALY DISEGN.: CR CONTR.: DM DATA: 18.04.02 MOD. 1:1 A3 0 CODICE SW060A-CF			

6) DIAGRAM OF THE ASSEMBLY

- 1) Main body
- 2) Inlet connection
- 3) Nozzle-holder
- 4) Nozzles
- 5) Identification plate

(06-000-00-EN)

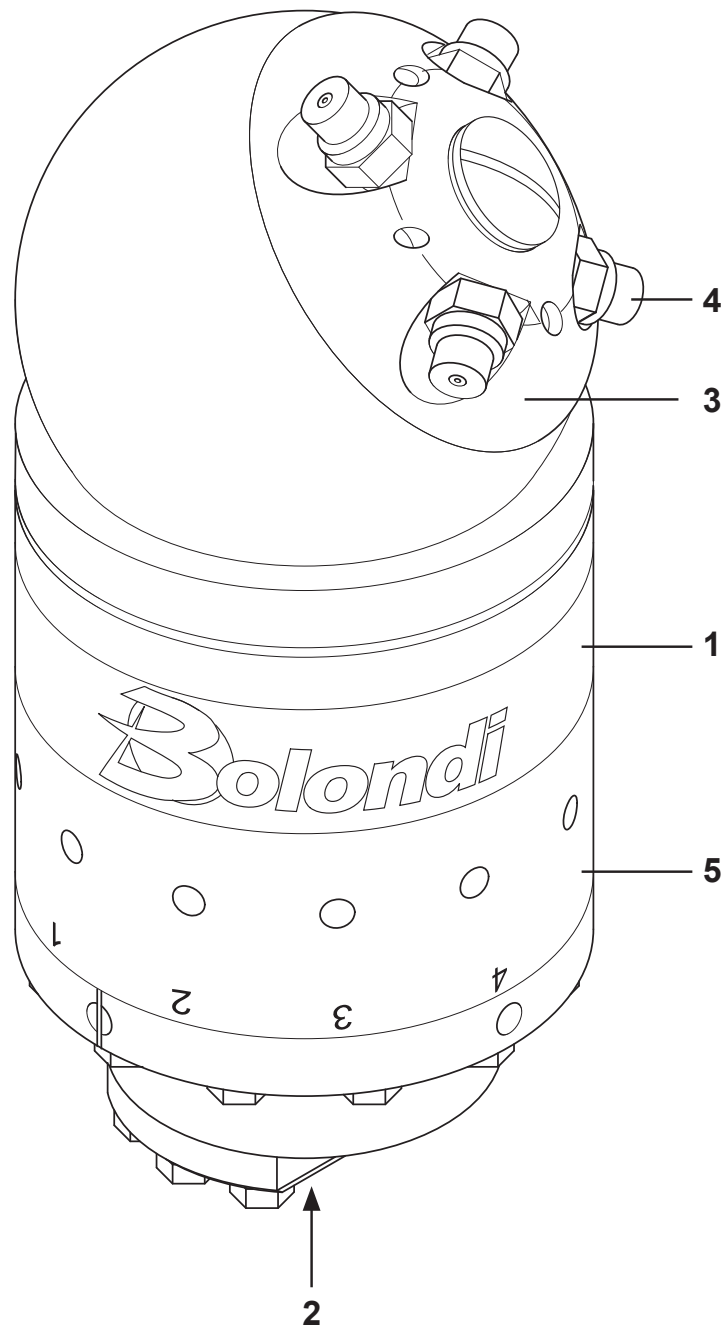



7) INSTALLATION AND COMMISSIONING (WARNINGS)



During installation and commissioning, comply with the indications in Chapter 04 of the General Safety Standards in this Manual. If the aforesaid indications are not complied with, the Manufacturer shall not be held liable.



See the Technical Data Chapter in the Manual for the pump/head connection and fastening.



Before switching on, it is advisable to flush the system to get rid of any waste or impurities.

Any breakage or problem due to waste and/or impurities is not covered by the warranty.



It is advisable to install a 60 micron filter between the head and the pump assembly.



Install a safety valve on the head delivery, set at the maximum pressure indicated on the rotating head or in the Technical Data Chapter in this Manual.



N.B. Do not turn the nozzle holder by hand

IMPORTANT: The head is calibrated with the specifications required in the order. If there are any changes to these parameters, please contact the Manufacturer. Any breakages or problems due to parameters that do not conform with specifications, shall not be covered by the warranty.

(07-AQM-00-EN)



8) SPINNING SPEED CONTROL

For best performance in relation to the pump flow rate (8-60 l/min.) the head should be set up as described below:

9) Loosen the 12 screws **pos.35** using a size 10 wrench.

10) Choose the spinning speed using table **A**, align the reference mark on the flange **pos.1** with the corresponding number printed on the diffuser **pos.33 (Fig.8.0 1, 2, 3, 4)**.

Tighten the screws **pos.35**.

(08- CA0500-00-EN)

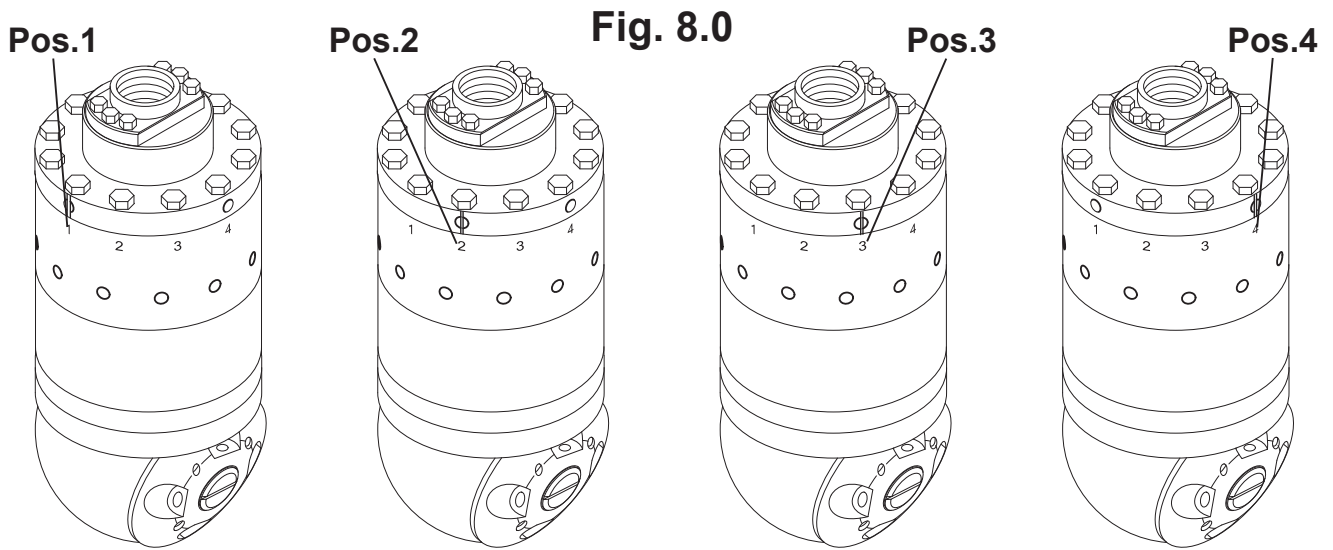

TABLE "A"		DIFFUSER POSITION			
		1	2	3	4
FLOW L / MIN	8	30			
	15	78	36		
	30		90	42	
	45			72	42
	60			96	60
SPINNING SPEED (RPM)					



9) MAINTENANCE

WARNING:

Disconnect the head from the hydraulic system before starting any routine or extraordinary maintenance.

(IMPORTANT: For all the numbers and references written in the chapter, please consult the exploded spare parts drawing).

(IMPORTANT: For all tightening jobs using a torque wrench, please consult table "B").

Lubricant recommended for maintenance: TUTELA Zeta2 NGLI 2

9.1) Cleaning the inlet filter pos. 63.

Disassembly

9.1.1) Unscrew and remove the screws pos. 61, disassemble the filter holder flange pos.62 and remove the cartridge pos.63 (Fig.9.0).

9.1.2) Clean the cartridge pos.63 thoroughly, make sure there are no breakages and fit back in place (pay attention, as per fig.9.1).

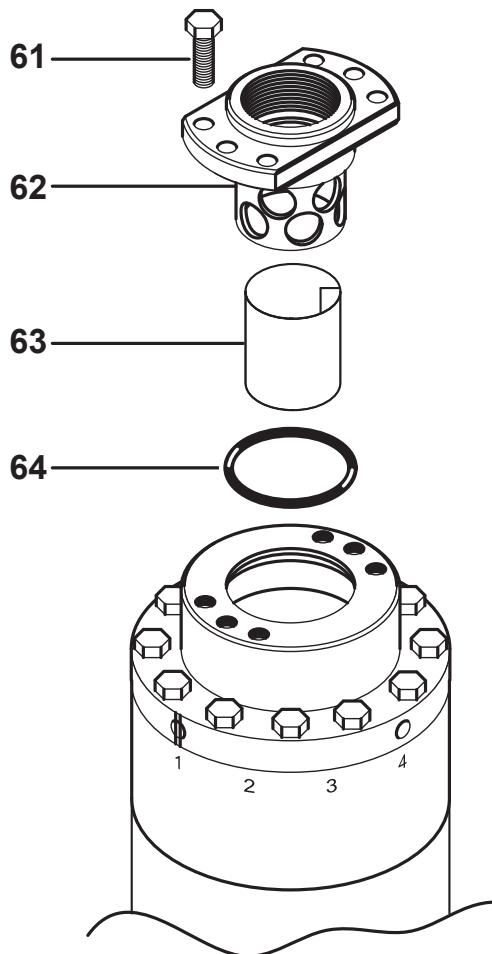

Fig. 9.0

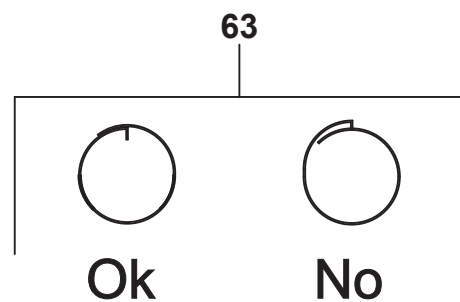

Fig. 9.1

Assembly

9.1.3) Lubricate the filter holder flange pos. 62 by the O-ring pos.64.

9.1.4) Put the filter holder flange pos. 62 back in its seat.

9.1.5) Screw the screws pos. 61, using a torque wrench.

9.2) Replacing the seals pos.23 on the nozzle holder pos.19.

Disassembly

9.2.1) Clamp the head in a bench vice and, using a suitable screwdriver, undo and remove the screw pos.22.

9.2.2) Remove the washer pos.24, pull the complete nozzle holder out pos.19 (Fig.9.2).

9.2.3) Using the dedicated tool, remove the seal and the O-ring pos.23 from their seats (Fig.9.3).

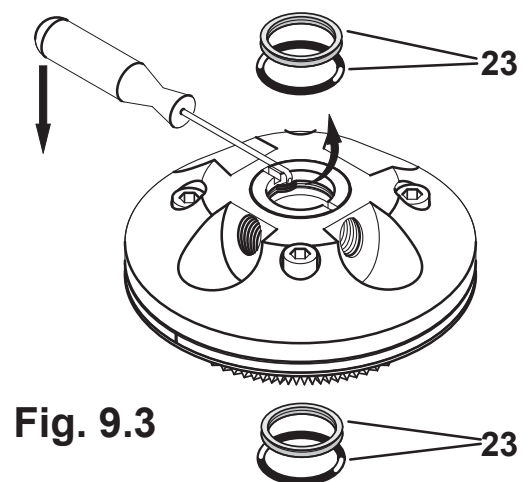
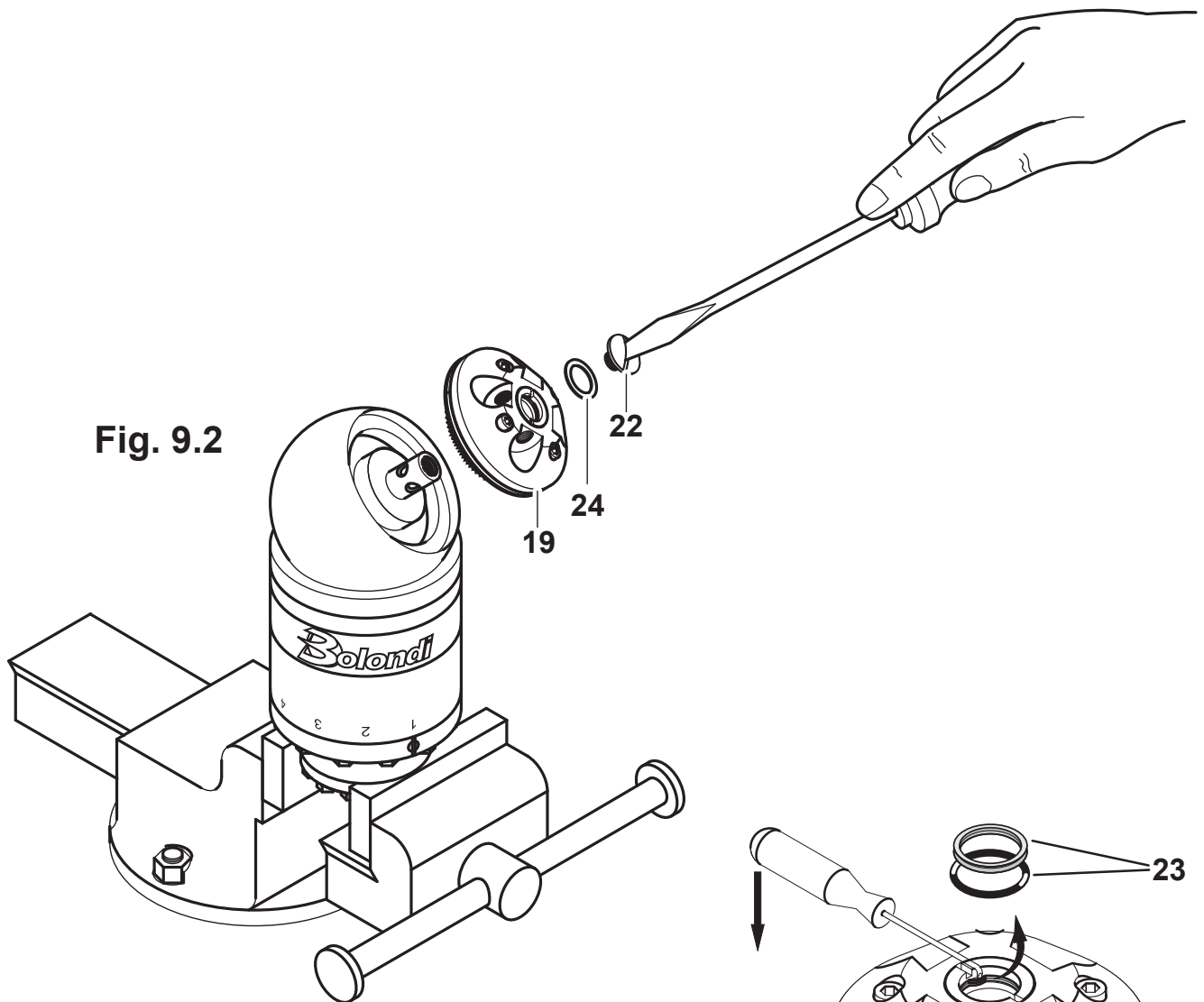

Assembly

9.2.4) First put the O-ring back in its seat and then the seal ring pos. 23 making it adhere perfectly to the O-ring using a

blunt tool. To make it easier to insert the ring, follow the instructions in fig.9.4.

9.2.5) Make sure everything is assembled correctly and greased.

9.2.6) Fit the nozzle holder unit on the pin pos.21.

9.2.7) Position the washer pos.24, put a few drops of Loctite 22 on the screw pos.22 and then mount it on the pin pos.21 and tighten definitively.

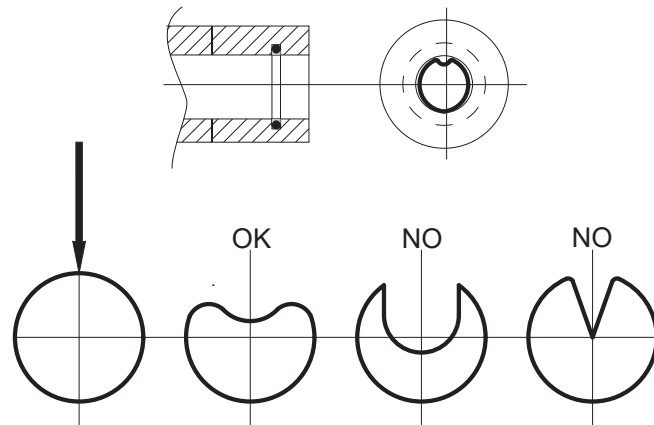

Fig. 9.4

9.3) Replacing the seals pos.23 on the bush pos.13.

Disassembly

9.3.1) Once the head has been removed, as in paragraph 9.1.2, remove the washer pos.20.

9.3.2) Keeping the spherical cap blocked pos.16 use a 13 mm ring spanner to undo and remove the nut pos.18.

9.3.3) Using a 5 mm. hex spanner undo and remove the dowel pos.14 and then remove the cap pos.16 (Fig.9.5).

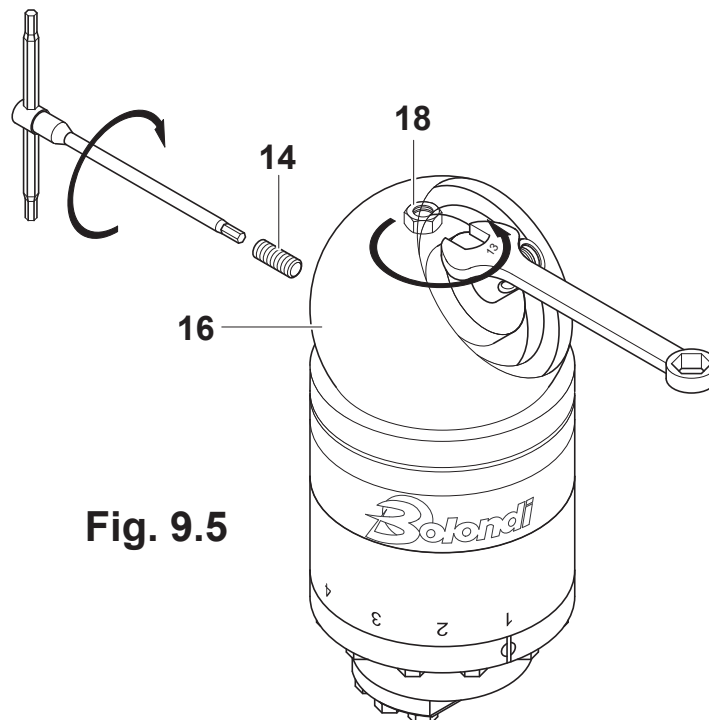

Fig. 9.5

9.3.4) Using a 6 mm. hex spanner undo and remove the 12 screws pos. 27 (Fig. 9.6).

9.3.5) Position the head as in fig.9.7 and dismantle the inlet unit.

9.3.6) Dismantle the impeller unit (kit "G"), the flange pos.5, the planetary gears pos.29 (kit "F") and the gear (kit "E") with relative washer pos.8 (Fig.9.8).

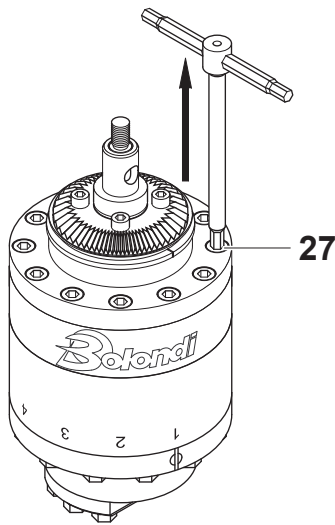

Fig. 9.6

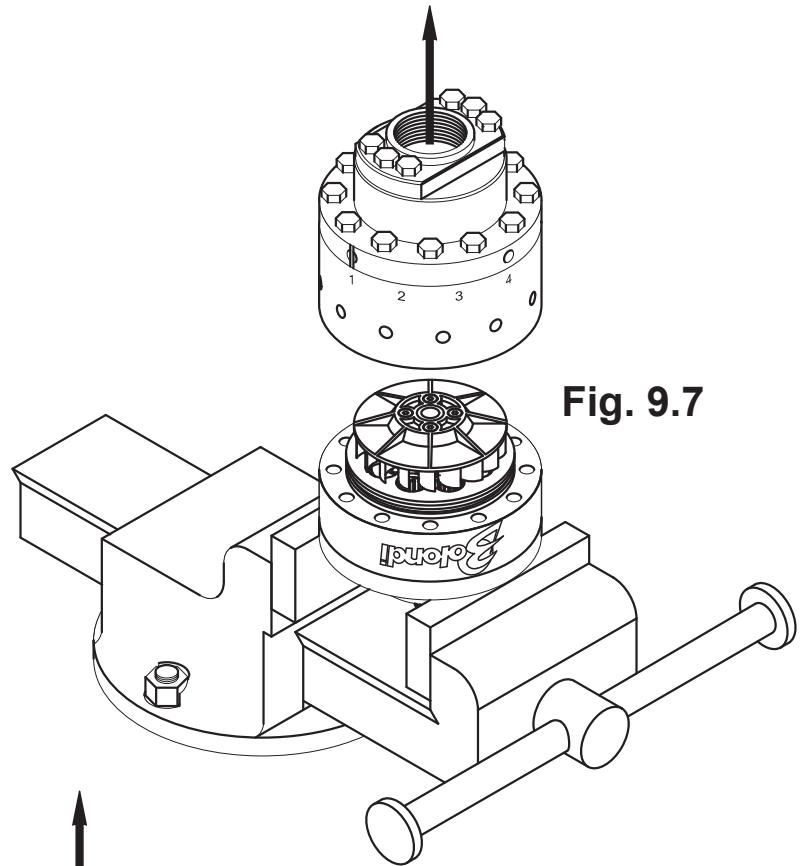

Fig. 9.7

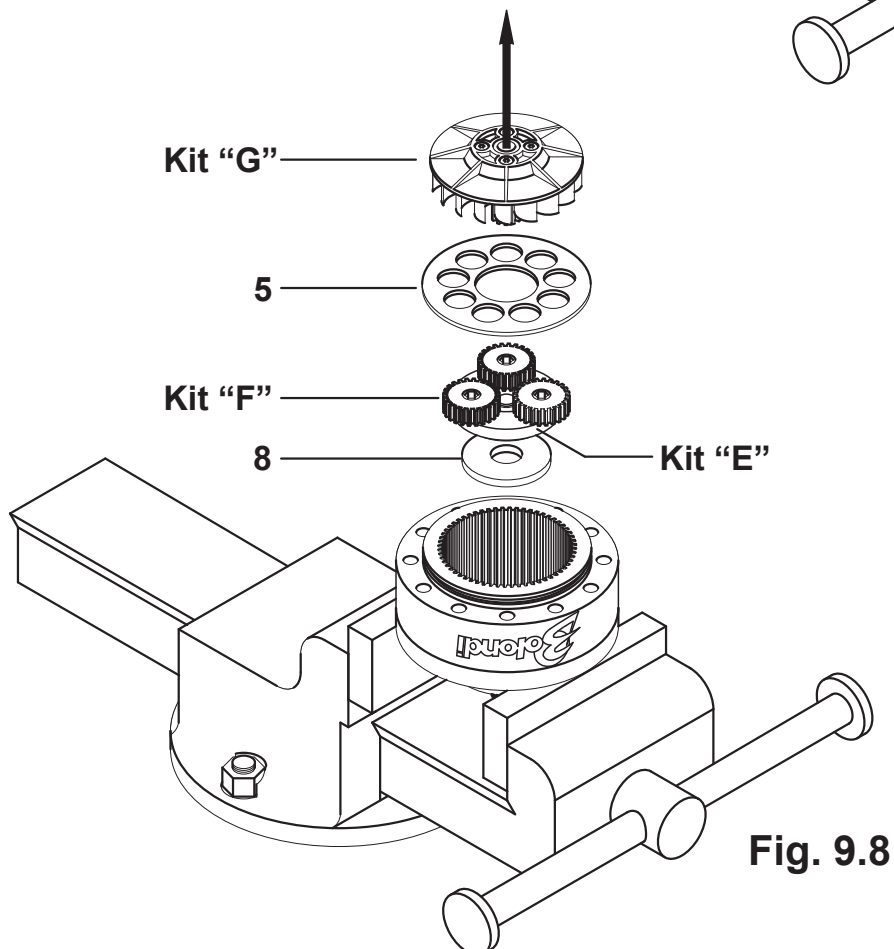

Fig. 9.8

9.3.7) Remove the crown pos.31 and the gears (kit "H") (Fig.9.9).

9.3.8) Remove the pin pos.26 (kit "D") and the parts pos.45-44-43-42 from the flange pos.48 (Fig.9.10).

9.3.9) Using a 4-mm hex spanner, undo and remove the screws pos.11, the pinion pos. 12 and the bush pos.13 from the flange pos.48 (Fig.9.11).

9.3.10) Using the dedicated tool, remove the seal and the O-ring pos.23 from their seats (Fig.9.12).

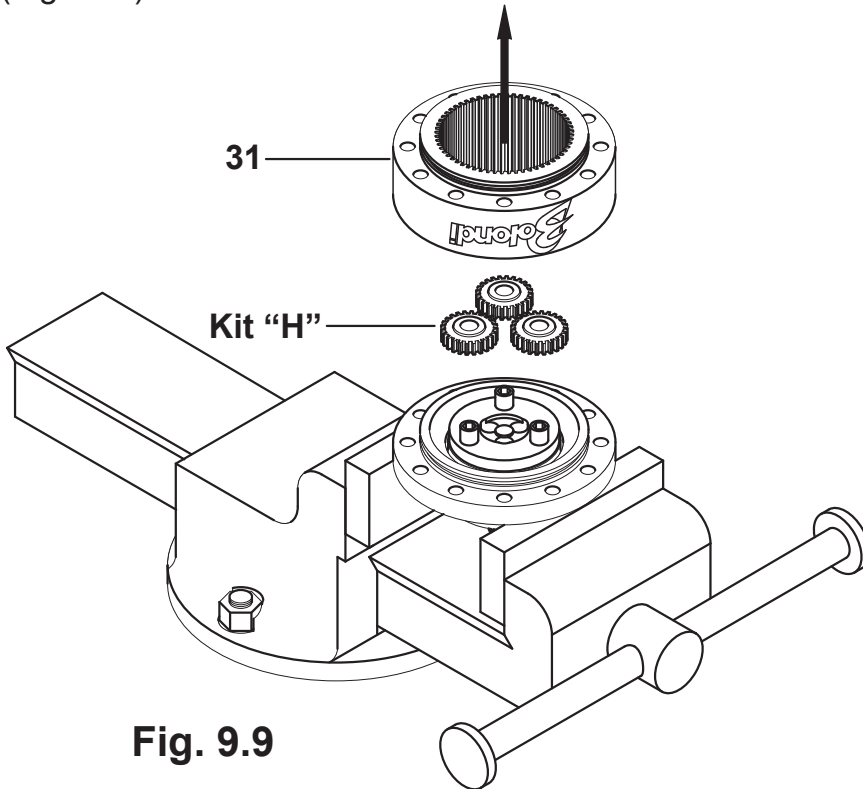

Fig. 9.9

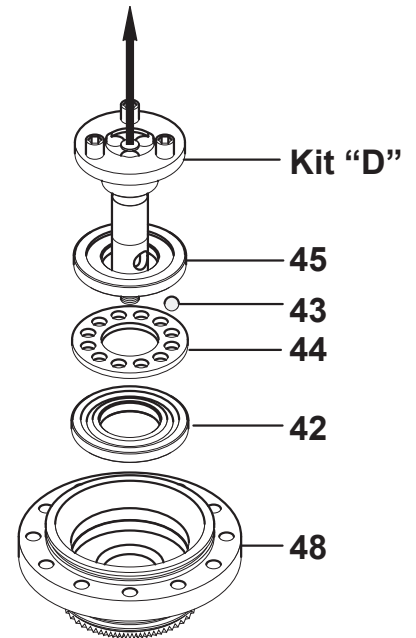

Fig. 9.10

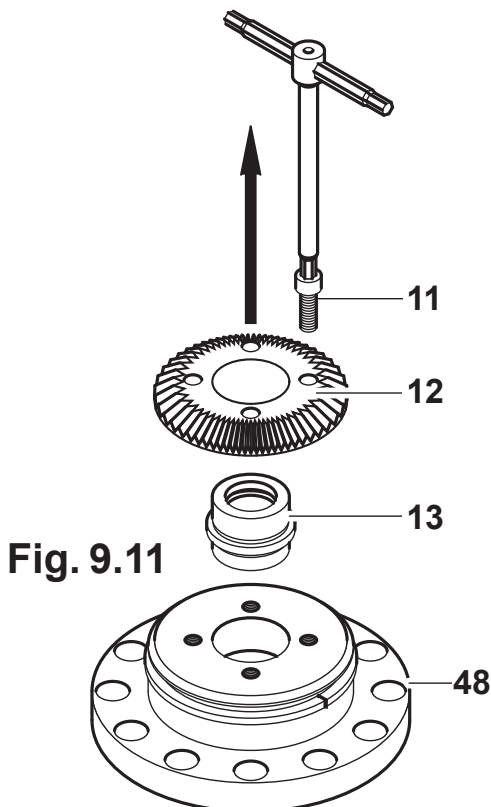

Fig. 9.11

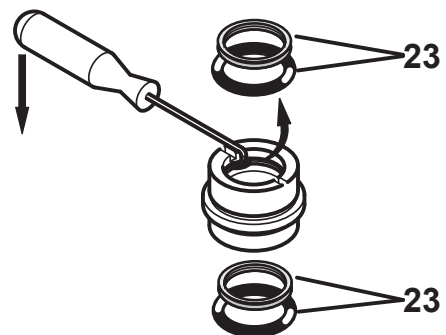

Fig. 9.12

Assembly

9.3.11) First put the O-ring back in its seat and then the seal ring pos. 23 making it adhere perfectly to the O-ring using a blunt tool. To make it easier to insert the ring, follow the instructions in fig.9.4.

9.3.12) Make sure everything is assembly correctly and greased.

9.3.13) Check the O-ring pos.40, replacing if necessary and greasing it.

9.3.14) Insert the bush pos.13 and the pinion pos.12 in the flange pos.48 and then lock it all with the screws pos.11 putting a drop of Loctite 222 on them (Fig.9.13).

9.3.15) Insert in sequence parts pos.42-44-43-45 and the output shaft kit "D" in the flange pos.48 (Fig.9.14).

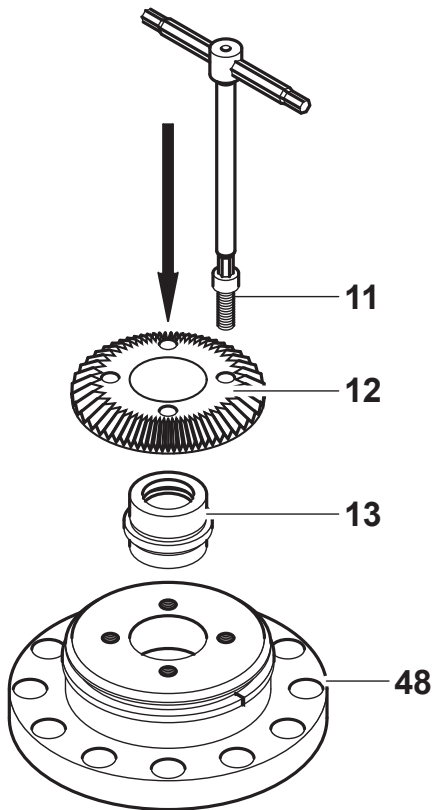

Fig. 9.13

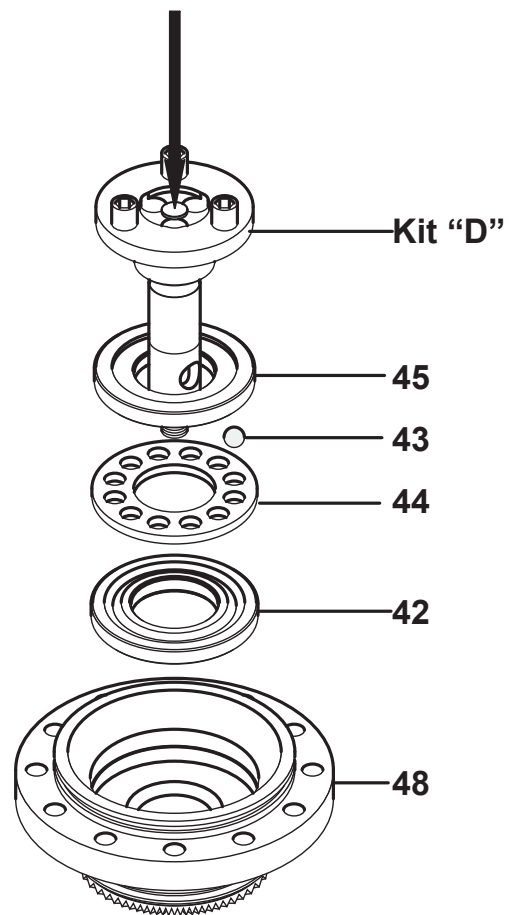
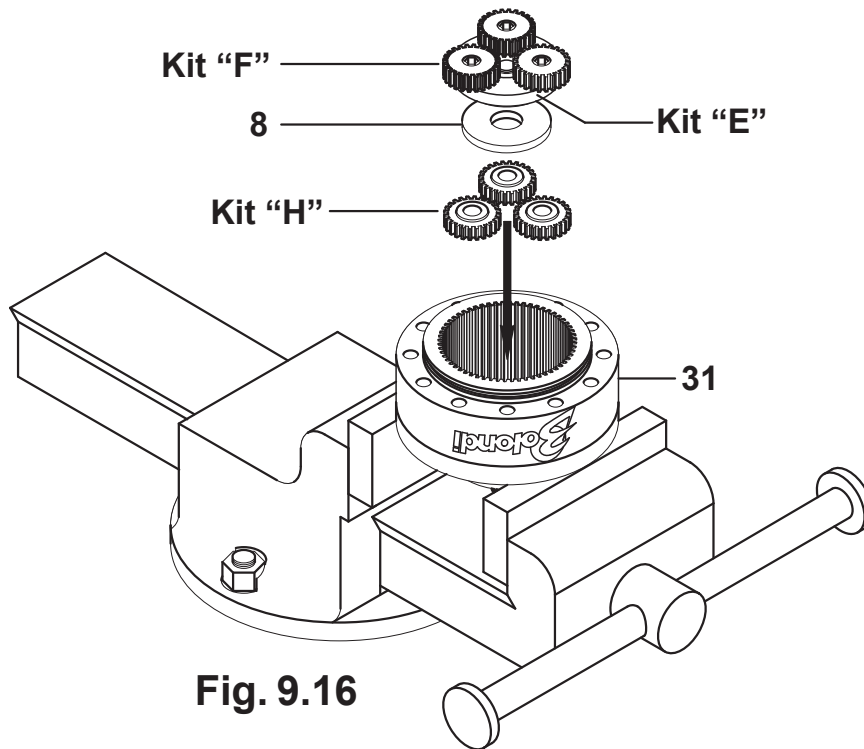
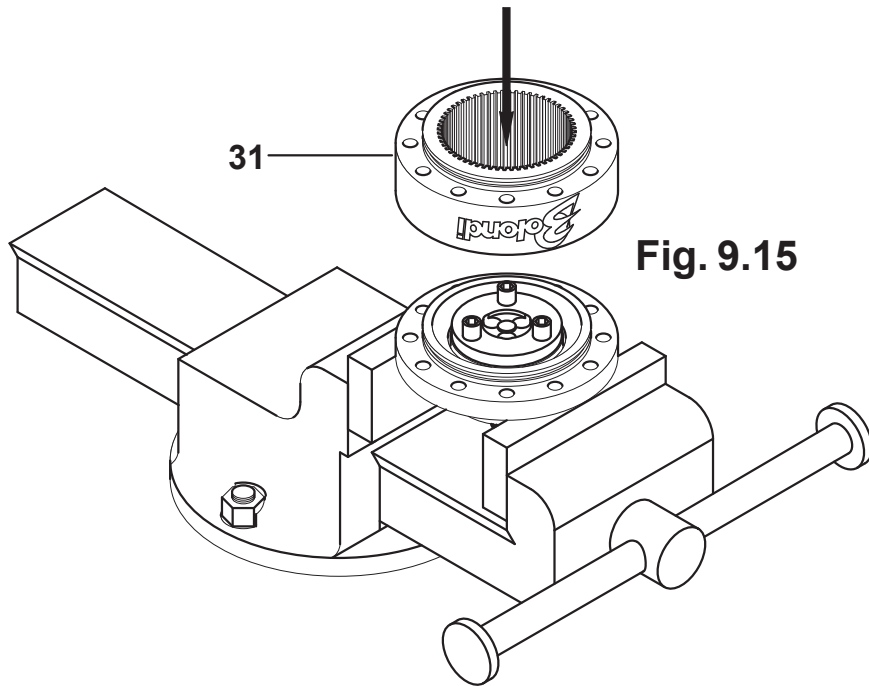

Fig. 9.14

9.3.16) Put the head back in the position shown in fig. 9.15 and fit the crown pos.31.

9.3.17) Fit the following in the given order: the planetary gears pos.48 (kit "H"), the washer pos.8, the gear kit "E" and the planetary gear kit "F", (Fig.9.16).



9.3.18) Position the flange pos.5 and the impeller kit "G" (Fig.9.17).

9.3.19) Fit the inlet unit and secure it with the screws pos.27.

9.3.20) Fit the spherical cap pos.16 on the output shaft pos.26 (kit "D") paying attention to the O ring pos.39.

9.3.21) Align the water outlet hole on the shaft pos.26 with the nozzle holder pin pos.21 which is on the cap pos.16 (Fig.9.18).

9.3.22) Put a few drops of Loctite 572 on the dowel pos.14, fit it on the cap pos.16 and tighten it temporarily.

9.3.23) Put a few drops of Loctite 222 on the part pos.15 which is on the shaft pos.26 (kit "D"), fit and tighten nut pos.18 on part pos.15.

Definitively tighten the dowel pos.14.

9.3.24) Position the washer pos.20 and complete assemble as in paragraph 9.1.6 – 9.1.7.

(00M-SW060CF-00-EN)

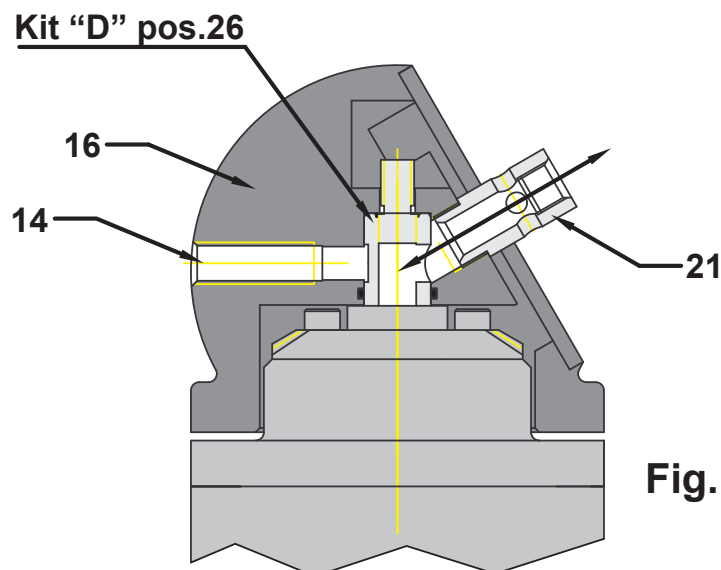
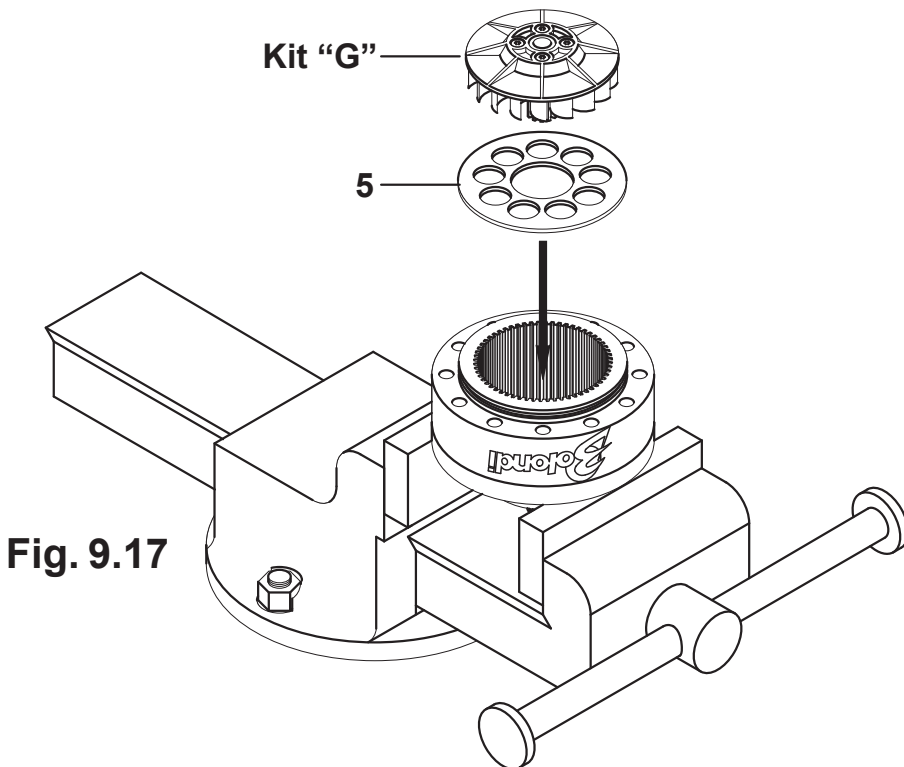

10) SPARE PARTS

Always refer to the spare parts tables when choosing spare parts. Spare parts should be requested by fax to following address:

Bolondi

Via A. Volta, 4 - 42027 MONTECCHIO (RE) - ITALY

Tel. +39 0522 864434 Fax +39 0522 865780

e-mail: bolondi@bolondi.com

always indicate:

- the model and serial number of the head (see identification plate)
- the code and description of the part ordered (see table)
- the quantity required
- the preferred means of shipment

(11-000-00-EN)

TABLE “B” TORQUE WRENCH SETTINGS

TABLE “B” TORQUE WRENCH SETTINGS		
Structural screws		
Pitch	Nm	
M5	7	All
M6	11	All
M8	20	All
M10 x 1,00	20	All
M14 x 1,00	35	All
Nozzles		
Pitch	Nm	
1/8 npt	5	All

EXPLODED VIEW

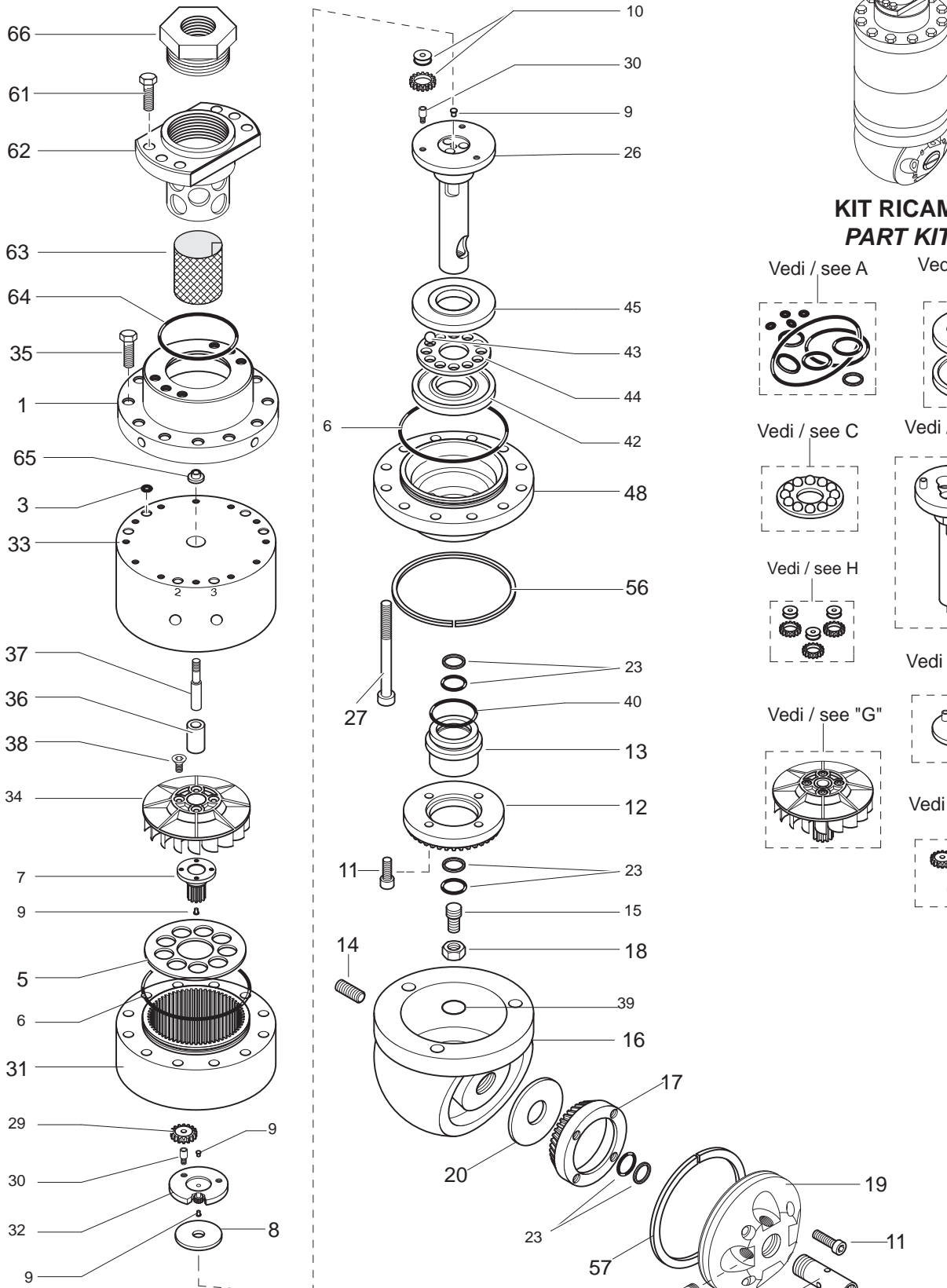

			VIA VOLTA 4 MONTECCHIO E. (RE) ITALY TEL. +39 522 864434 FAX +39 522 865780 E-Mail bolondi@bolondi.com	
	MODELLO: SW 060-CF		DISEGN.: LP	
	NOTE:		Versione: 09	
			Data: 01.01.2012	



Via A.Volta, 4
Tel. (0522) 864434 - Fax 865780
42027 MONTECCHIO E. (Reggio E.) Italy

E-mail: bolondi@bolondi.com
Web site: <http://www.bolondi.com>